

3U OpenVPX Module Xilinx Zynq UltraScale+ MPSoC with FMC HPC Site

Overview

PanaTeQ's **VPX3-ZU1** is a 3U OpenVPX module based on the Zynq UltraScale+ MultiProcessor SoC device from Xilinx.

The Zynq UltraScale+ integrates a Quad-core ARM Cortex-A53 based Application Processing Unit (**APU**), a Dual-core ARM Cortex-R5 based Real-Time Processing Unit (**RPU**), a ARM Mali-400 based Graphic Processing Unit (**GPU**) and an UltraScale+ Programmable Logic (**PL**) in a single device. It also includes on-chip memory, external memory interfaces, and a rich set of peripheral connectivity interfaces.

The board can be ordered with different versions of the Zynq UltraScale+ family of devices, coupled up to 8GB 64-bit DDR4-2400 Processing Memory with 8-bit ECC.

Up to 2GB 16-bit of DDR4-2400 is also available as the Programmable Logic Memory, allowing data streaming applications such as video CODEC and signal processing. 64GB of soldered eMMC managed NAND Flash is available for local data storage.

The VPX3-ZU1 uses four advanced DC/DC power modules from Linear Technology using PMBus and PanaTeQ's **Smart Power Management** technology.

For front-end I/O interfaces, an on-board **FMC** site compliant to the Vita 57.1 HPC standard with 90 SE IO (45 Diff Pairs) and 10 MGT, allowing a wide range of applications such as Software Defined Radio, Video Camera Processing, advanced Multi-Axes Motors controller, Multi-Gig Ethernet Communications, LIDAR/RADAR/SONAR.

The board can act as a **Single Board Computer** in the VPX system thanks to its on-board PCIe Gen2 Switch. When the VPX3-ZU1 is System Controller, it can manage up to eight 3U OpenVPX slots with a PCIe x1 Gen2 link per slot. There is no need to add any SBC in the VPX System, improving **Size, Weight, Power and Cost (SWaP-C)**.

A large number of the Zynq Ultrascale+ PS peripherals are available on the VPX backplane: 1x ETH 1000Base-T, 2x USB 3.0/2.0, 2x USB 2.0, 1x SATA 3.1, 2x CAN-2.0B, 2x RS-232/422/485, 4x MGT, 20x GPIO, Video Out Display Port 1.2.

The air cooled PanaTeQ System Development Kit **VPX3-ZU1-PSDK** is available for the developers and includes a lab chassis with 5-slots Full-Mesh backplane, the VPX3-ZU1-B1N-AS and RTM-ZU1 boards, a PentLinux BSP, PanaTeQ FPGA Design Kit (**PAN-FDK**) and cables.

Key Features

- 3U VITA 46.0 46.4 65.0 57.1 Compliant
- Xilinx Zynq UltraScale+ MPSoC
- ZU6G/ZU9G/ZU15G FFVC-900 Package
- Up to 8GB DDR4-2400 64-bit PS memory with 8-bit ECC
- Up to 2GB DDR4-2400 16-bit PL memory
- eMMC 64GB (V4.51), MRAM 512KB
- On-board PCIe Gen2 Switch 16-Lanes 16-Ports with NT support
- 4x MGT on VPX-P1 Expansion Plane
- 1x Display Port 1.2 Video Out on VPX-P2
- 2x ETH 1000Base-X/SGMII on VPX-P1 Control Plane
- 1x ETH 1000Base-T on VPX-P2
- 2x USB 3.0, 2x USB 2.0, 1x SATA 3.1 on VPX-P2
- 20x LVCMOS or 10x LVDS GPIO on VPX-P2
- 2x RS.232/422/485, 2x CAN 2.0B on VPX-P2
- FMC HPC site with 90x IO / 45x LVDS, 10x MGT
- Smart Power Management using 4x LTM467x with PMBus
- Board Management Controller ARM Cortex-M3 based
- VPX System Controller
- Air Cooled and Conduction Cooled

Typical Applications

- MILCOM, Software Defined Radio, MIMO
- Situational Awareness Systems
- Electronic Warfare, Signal Intelligence
- LIDAR/RADAR/SONAR Systems
- Advanced Multi-Axes Motors Control
- Video CODEC and Signal Processing

VPX3-ZU1 3U VPX Zynq UltraScale+ Module

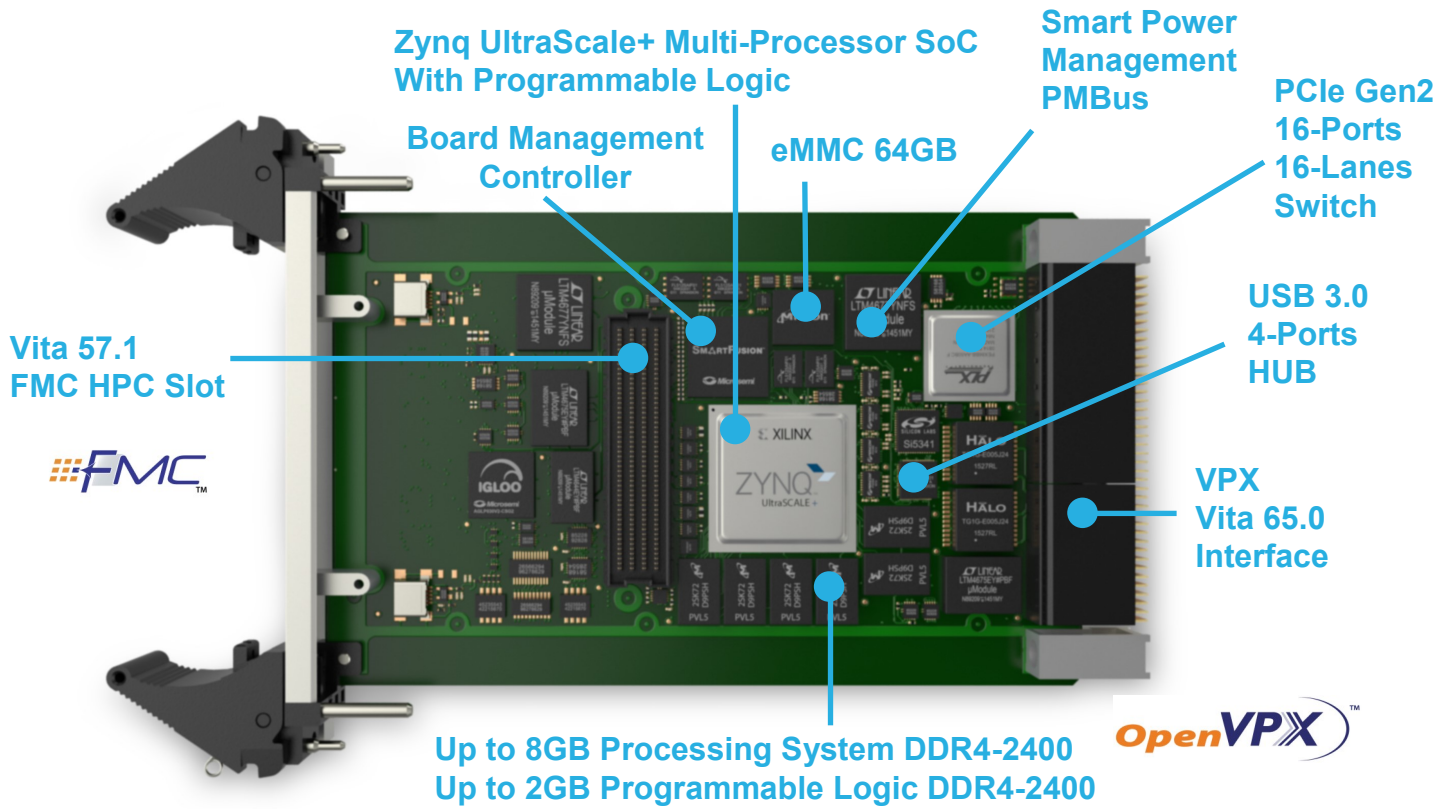

Bloc Diagram

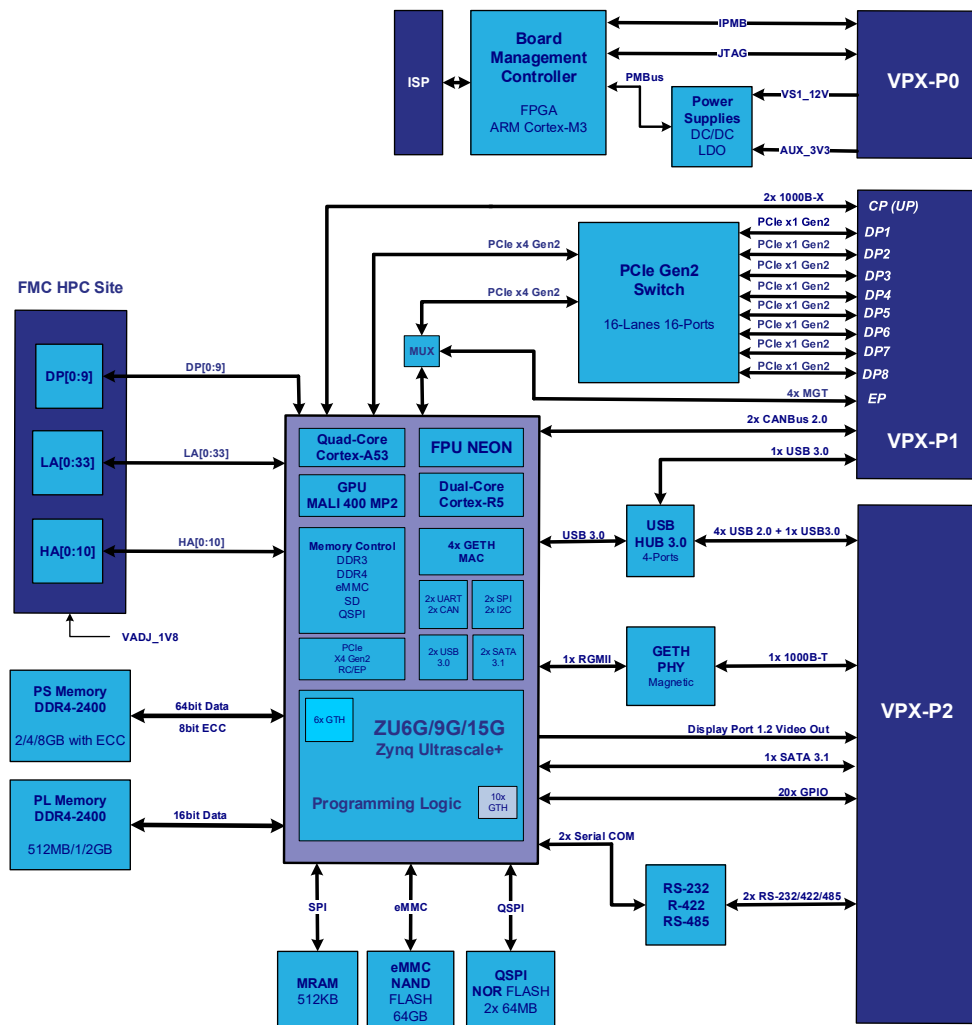

Xilinx Zynq Ultrascale+ MPSoC Processing System Highlights

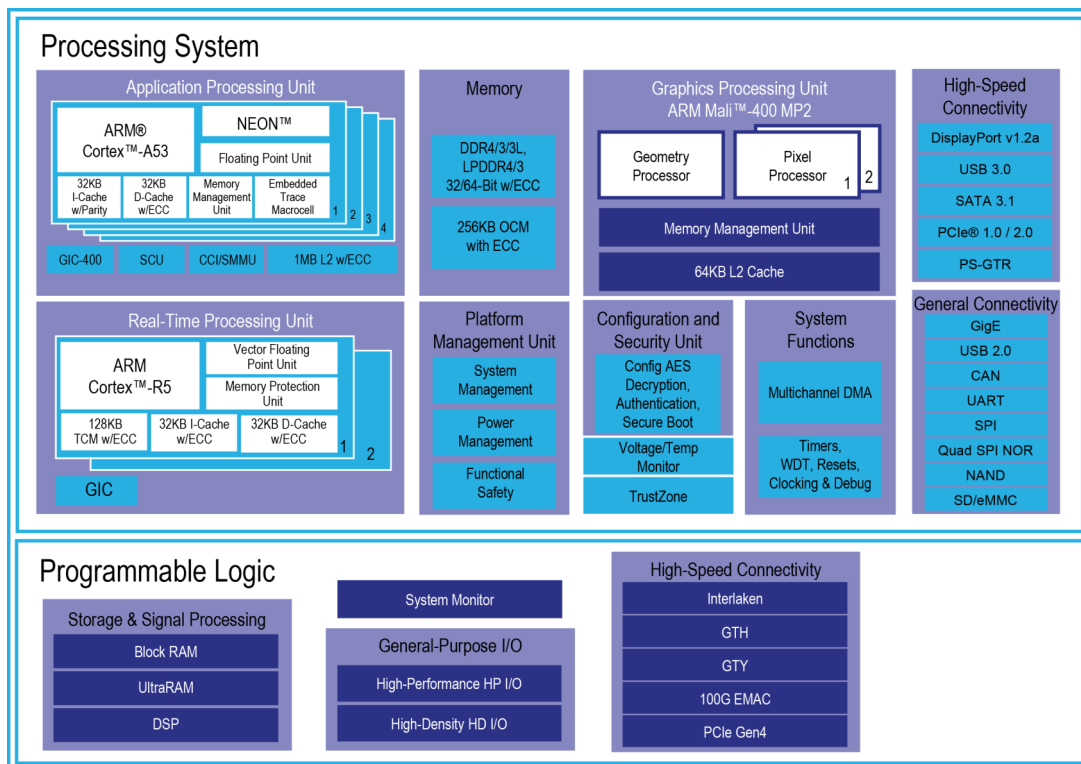

Applications processing unit (APU) with quad-core ARM® Cortex™-A53 processors up to 1.5GHz:

- Next-generation ARMv8 architecture supporting 32- or 64-bit data widths
- Ideal for Linux and bare-metal SMP/AMP application systems

Real-time processing unit (RPU) with dual-core ARM Cortex-R5 processors up to 600MHz:

- Low-latency, highly deterministic performance APU offloading

New integrated hardened multimedia blocks up to 667MHz:

- Graphics processing unit (GPU) [ARM Mali™-400MP2]
- 4Kx2K 60fps video encoder/decoder (VCU) [in select devices]
- 4Kx2K 30fps DisplayPort interface

New integrated high-speed peripherals:

- PCIe® Gen1 or Gen2 root complex and integrated Endpoint block in x1, x2, and x4 lanes
- USB 3.0/2.0 with host, device, and OTG modes
- Gigabit Ethernet with jumbo frames and precision time protocol
- SATA 3.1 host
- Dedicated quad transceivers up to 6Gb/s

General and boot peripherals:

- CAN, I2C, QSPI, SD, eMMC, and NAND flash interfaces
- GPIO, UART, and trace ports
- 6-port DDR controller with ECC, supporting x32 and x64 DDR3, DDR3L, LPDDR3, LPDDR4, DDR4
- Integrated platform management unit (PMU) supporting multiple power domains
- Integrated configuration security unit (CSU)
- TrustZone support
- Peripheral and memory protection

Board Specifications

3U VPX Interfaces

- VITA 46.0/46.4/65.0 VPX/OpenVPX Specifications compliant
- On-board PCIe Gen2 NT Switch 2x PCIe x4 or 8x PCIe x1 Gen2 links connected to Zynq Ultrascale+ Processing System
- 4x MGT GTH @ up to 16.3 Gb/s connected to/from Zynq Ultrascale+ Programming Logic
- 2x1000BASE-X/SGMII links on VPX Control Plane
- 1x1000BASE-T, 2x RS-232/422/485, 2x USB 3.0/2.0, 2x USB 2.0, 1x SATA 3.1, 2x CAN 2.0B, 20x GPIO
- 1x Display Port 1.2 VIDEO OUT
- Board Management Controller (BMC) Interface. VITA 46.11 Ready
- System Controller capability
- JTAG

OpenVPX VITA 65.0 Profiles

- MOD3-PAY-2F2U-16.2.3-2, MOD3-PAY-2F2U-16.2.3-3
- MOD3-PAY-8U-16.2.9-1, MOD3-PAY-8U-16.2.9-2
- MOD3-PAY-2F4F2U-16.2.10-3, MOD3-PAY-2F4F2U-16.2.10-4

Xilinx Zynq Ultrascale+ MPSoC

- Supported Devices: **XVZU6EG-1FFVC900** / **XCZU9EG-1FFVC900** / **XCZU15EG-1FFVC900** (Speed Grade –1/2/3)
- Processing System : Quad-Core ARM A53, Dual-Core ARM R5, GPU Mali-400, 2x SATA, 2x USB, 4x GETH MACs
- Programmable Logic: 469K Logic Cells (ZU6EG) / 600K Logic Cells (ZU9EG) / 747K Logic Cells (ZU15EG)
- On-Chip Memories: 25.1Mb (ZU6EG) / 32Mb (ZU9EG) / 57.7Mb (ZU15EG)
- DSP Slices: 1973 (ZU6EG) / 2520 (ZU9EG) / 3528 (ZU15EG)
- High Speed Serial Links: 16 full duplex, high performance, GTH Multi-Gigabit Transceivers (MGT) @ up to 16.3 Gb/s
- 2x 10-bit, 1MSPS ADCs for System Monitoring
- Supported by PanaTeQ's FPGA Development Kit (**PAN-FDK**)

External Memories

- Up to 8GB of DDR4-2400 Processor System (PS) memory, 64-bit data, 8-bit ECC
- Up to 2GB of DDR4-2400 Programmable Logic (PL) memory, 16-bit data, no ECC
- 64GB eMMC v4.51 of managed NAND Flash memory. HS200 support @ up to 100MB/s
- 512KB of SPI MRAM (NVRAM)
- 2x 512Mb of QSPI NOR Flash memory for booting Zynq Ultrascale+ Programmable Logic and Firmware Processing System

VITA 57 FMC Slot

- Compliant to the High Pin Count (HPC) VITA 57.1 specification
- 10x high-performance MGT @ up to 16.3 Gb/s to/from Zynq Programmable Logic
- 90 LVCMOS_18 or 45 LVDS_18 (LA [0:33], HA[0:10]) to/from FPGA Zynq Ultrascale+ Programmable Logic
- 2x clocks FMC to Zynq Ultrascale+ Programmable Logic
- 2x clocks FMC to Zynq Ultrascale+ GTH Transceivers
- VADJ = 1V8 (default). 2V5 not supported by Zynq Ultrascale+ HP Banks

Board Management Controller (BMC)

- Based on Microsemi SmartFusion Customizable System-on-Chip (**csoc**) with on-chip ARM Cortex-M3 at up to 100MHz
- Real-Time Monitoring+Alarms: Voltages, Currents, Temperatures, 6-Axis Accelerometer, Magnetometer and Humidity
- Reset Management, Power-Up and Power-Down Sequencing. Built-In Test (**BIT**)
- Watchdogs (Avionics type)
- Large private 32MB Event Log Flash Memory.
- UART communication with host using RTM-ZU1 Rear-Transition Module
- Smart Power Management using four LTM467x Linear Technology DC/DC modules with Digital Power System Management
- Hardware Ready for full Vita 46.11 compliance

Environnemental Specifications

- Compliant with VITA 47 specification. Please contact PanaTeQ for more information

Product Codification

The VPX3-ZU1 can be assembled with different versions of the Zynq Ultrascale+ devices and various amounts of memory storage. The cooling technique and ruggedization level are also available options. The following table shows the product coding for all these options.

VPX3-ZU1-B 2 M-AS

	Device	ARM A53 Cores	GPU	System Logic Cells	DSP Slices	Memory
A	XCZU6EG	4	Yes	469K	1973	25.1 Mb
B	XCZU9EG	4	Yes	600K	2530	32 Mb
C	XCZU15EG	4	Yes	747K	3528	57.7 Mb
D	XCZU6CG	2	No	469K	1973	25.1 Mb
E	XCZU9CG	2	No	600K	2530	32 Mb

	Device Speed Grade
1	Slowest
2	Mid
3	Fastest

	PS / PL Memory Size
N	2GB/512MB
M	4GB/1GB
P	8GB/2GB

	Ruggedization Level	VITA 47
AS	Air Standard	EAC4
AR	Air Rugged	EAC6
CC	Conduction Cooled	ECC3
CR	Conduction Rugged	ECC4

Ordering Information

The following product references are offered by Panateq as standard products. Other combinations of devices, speed grade, memory and cooling can be specially ordered. Please contact us for details

Reference	Device	Speed Grade	Memory PS/PL	Ruggedization Level
VPX3-ZU1-A1N-AS	ZU6EG	-1	2GB/512MB	Standard Air Cooled
VPX3-ZU1-A1N-CC	ZU6EG	-1	2GB/512MB	Conduction Cooled
VPX3-ZU1-A1M-AS	ZU6EG	-1	4GB/1GB	Standard Air Cooled
VPX3-ZU1-A1M-CC	ZU6EG	-1	4GB/1GB	Conduction Cooled
VPX3-ZU1-B1N-AS	ZU9EG	-1	2GB/512MB	Standard Air Cooled
VPX3-ZU1-B1N-CC	ZU9EG	-1	2GB/512MB	Conduction Cooled
VPX3-ZU1-B1M-AS	ZU9EG	-1	4GB/1GB	Standard, Air Cooled
VPX3-ZU1-B1M-CC	ZU9EG	-1	4GB/1GB	Conduction Cooled
VPX3-ZU1-C1N-AS	ZU15EG	-1	2GB/512MB	Standard, Air Cooled
VPX3-ZU1-C1N-CC	ZU15EG	-1	2GB/512MB	Conduction Cooled
VPX3-ZU1-C1M-AS	ZU15EG	-1	4GB/1GB	Standard, Air Cooled
VPX3-ZU1-C1M-CC	ZU15EG	-1	4GB/1GB	Conduction Cooled

Reference	Description
RTM-ZU1-A1	Rear Transition Module for VPX3-ZU1
VPX3-ZU1-PSDK	VPX3-ZU1 System Development Kit